



# Shaft Collar Standard / Compact with Urethane Clamp / Split

**Features:** Standard with Urethane: Reduces noises generated by metal-to-metal contact.  
Compact with Urethane: Smaller by up to 44% in width (B dimension) and 25% in O.D. (D<sub>1</sub> dimension) than Standard Type with Urethane.

**Standard with Urethane, Clamp Type**



**Standard with Urethane, Split Type**



Type	Clamp	Split	Material	Surface Treatment	Accessory
SCD	SCSPD		EN 1.1191 Equiv.	Black Oxide Coating	Clamp: Hex Socket Head Cap Screw 1 pc. Split: Hex Socket Head Cap Screw 2 pcs. EN 1.7220 Equiv.
PSCD	PSCSPD			Electroless Nickel Plating	Clamp: Hex Socket Head Cap Screw 1 pc. (Stainless Steel) Split: Hex Socket Head Cap Screw 2 pcs. (Stainless Steel) EN 1.4301 Equiv.
SSCD	SSCSPD		EN 1.4301 Equiv.	-	EN 1.4301 Equiv.

**Material:** Urethane (Shore A70: No.3-6 (Ester Type), No.8-50 (Ether Type))  
**Hardness:** Clamp (Shore A70 (Ester Type), No.8-50 (Ether Type))  
**Split:** (Allowable Temperature: 70°C)  
**Urethane Rubber Features:** P.2-389

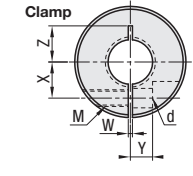
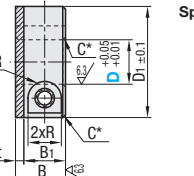
**Dimensions:** D<sub>1</sub> tolerance: +0.01 to +0.08. \*D3 ~D13: C0.5, D15~D50: C1.

Part Number Type	D	B	D <sub>1</sub>	B <sub>1</sub>	t	M (Coarse)	d	R	W	X	Y	Z	Unit Price						
													SCD	PSCD	SSCD	SCSPD	PSCSPD	SSCSPD	
(Clamp) SCD PSCD SSCD	*3	10	15	8	2	M3	3.4	3	1.0	4.5	3	3~5							
	*4	12	20	10		M4	4.5	3.75		6	4	3.5~6							
	*5	18	35	15	3	M6	7	6	1.5	9	5	6~6.5							
	*6	40	10							7~10									
	*8	50	11							8~12.5									
	(Split) PSCSPD SSCSPD	*10	20	55	5	5	M8	9	7	2.0	11	6	9~12.5						
		*12	60	13							10~12.5								
		*13	70	15							11~13								
		*15	85	22	13~15														
		*16	23	70	18	M8	9	7	2.0	26	13	20~23							
*20		27	85	22	M10	11	9	2.0	32	16	25~28								

**Compact with Urethane, Clamp Type**



**Compact with Urethane, Split Type**



Type	Clamp	Split	Material	Surface Treatment	Accessory
SCDJ	SCSPDJ		EN 1.1191 Equiv.	Black Oxide Coating	Clamp: Hex Socket Head Cap Screw 1 pc. Split: Hex Socket Head Cap Screw 2 pcs. EN 1.7220 Equiv.
PSCDJ	PSCSPDJ			Electroless Nickel Plating	Clamp: Hex Socket Head Cap Screw 1 pc. (Stainless Steel) Split: Hex Socket Head Cap Screw 2 pcs. (Stainless Steel) EN 1.4301 Equiv.
SSCDJ	SSCSPDJ		EN 1.4301 Equiv.	-	EN 1.4301 Equiv.

**Material:** Urethane (Shore A70)  
**Hardness:** Shore A70 (Allowable Temperature: 70°C)  
**Urethane Rubber Features:** P.2-389

Refer to Size Comparison Table below.

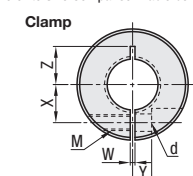
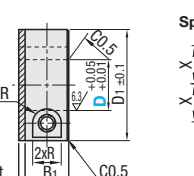
**Dimensions:** D<sub>1</sub> tolerance: +0.01 to +0.05. \*D3 ~D13: C0.5, D15~D50: C1.

Part Number Type	D	B Selection	D <sub>1</sub>	B <sub>1</sub>	t	M (Coarse)	d	R	W	X	Y	Z	Unit Price						
													SCDJ	PSCDJ	SSCDJ	SCSPDJ	PSCSPDJ	SSCSPDJ	
(Clamp) SCDJ PSCDJ SSCDJ	8	10	25	8	2	M3	3.4	3	1.5	8	5	7~9							
	10		30							9	5	8~10							
	12	35	10	6	9~10														
	16	40	12	7	11~12														
	20	45	13	7	13														
	(Split) PSCSPDJ SSCSPDJ	25	15	45	12	3	M5	5.5	4.5	2	17	6	16						
		30		60							20	6	18~20						
		*40	80	18	2	25	6	23											
		*50	21	80	18	M8	9	7	3	32	15	28							

Ordering Example: SCSPD8 - B, SCSPD10 - 10, SCSPD12 - 10

**Size Comparison Table**

D	Size Differences		Compact		Standard	
	B (Thickness)	D <sub>1</sub> (O.D.)	B (Thickness)	D <sub>1</sub> (O.D.)	B (Thickness)	D <sub>1</sub> (O.D.)
8	-8	-5	10	25	18	30
10	-8	-5	10	30	18	35
12	-8	-10	10	30	18	40
16	-6	-5	12	35	18	40
20	-7	-5	13	40	20	45
25	-5	-5	15	45	20	50
30	-5	-5	15	50	20	55
40	-8	-10	15	60	23	70
50	-6	-5	21	80	27	85

# Shaft Collar Threaded Inserts (Lightweight) Plastic / Aluminum

**Features:** Aluminum or plastic collars are lighter than those of steel or stainless steel.  
Collars with threaded inserts have improved screw thread strength.

**Plastic**



Type	Clamp	Split	Material	Color	Operating Ambient Temperature	Accessory	Threaded Insert Material
SCSPH	SCSPH	SCSPP	Polyacetal	White	-45°C~95°C	Hex Socket Head Cap Screw EN 1.4301 Equiv.	EN 1.4301 Equiv.
SCSMH	SCSMH	SCSPM	MC Nylon	Ivory	-40°C~120°C	Clamp Type: 1 pc. Split Type: 2 pcs.	EN 1.4301 Equiv.
SCSPO			Polyacetal	White	-45°C~95°C		Not provided

**Dimensions:** \*D8~D25: C0.5, D30: C1.

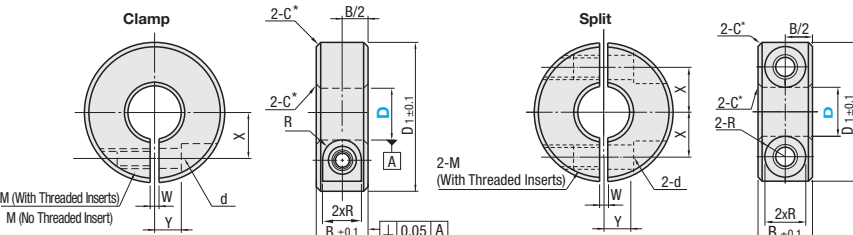

Part Number Type	D	B	D <sub>1</sub>	M (Coarse)	d	R	W	X	Y	Unit Price			
										SCSPH	SCSMH	SCSPP	SCSPM
With Threaded Inserts (Clamp) SCSPH SCSMH (Split) SCSPP SCSPM	8	10	8	M3	3.4	3	1.5	7	5				
	10		25	9									
	12	30	10	M4	4.5	3.75	10						
	15	35	12	M5	5.5	4.5	12	6					
	16	45	15	M6	6.6	6	15	8					
	20	50	18										
	25	55	20										

The halves must remain in the same orientation as shipped when in use.

Part Number Type	D	B	D <sub>1</sub>	d	M (Coarse)	R	W	X	Y	Unit Price	
										SCSPO	
No Threaded Insert (Clamp) SCSPO	10	12	12	4.5	M4	3.75	1.5	9	5		
	12		28					10	6		
	13	30	13	8							
	15	40	16	6							
	16	49	20	6							
	20	54	21.5	8							
	25	60									

**Aluminum Type**



Type	Clamp	Split	Material	Surface Treatment	Accessory	Threaded Insert Material
SCSAH	SCSAH	SCNPAH	Aluminum Alloy 2000 series	-	Hex Socket Head Cap Screw EN 1.4301 Equiv. Clamp Type: 1 pc. Split Type: 2 pcs.	EN 1.4301 Equiv.

**Dimensions:** \*D8~D25: C0.5, D30: C1.

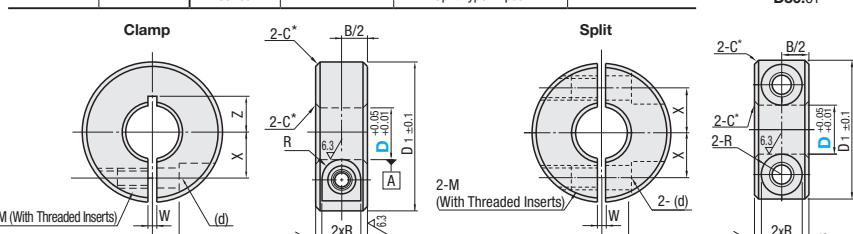

Part Number Type	D	B Selection	D <sub>1</sub>	M (Coarse)	d	R	W	X	Y	Z	Unit Price	
											SCSAH	SCNPAH
With Threaded Inserts (Clamp) SCSAH (Split) SCNPAH	8	8	25	M3	3.2	3	1.5	7	5	7		
	10		30	M4	4.2	3.75		9		8		
	12	34	10	6	10							
	15	35	11.5	6	11							
	16	40	12	7	13							
	20	45	17	7	16							
	25	45	20	10	18							
	30	55	15	6	20	10	18					

(d) bore surface will have threads from installing the inserts.

Ordering Example: SCSPH12 - B, SCSPP12 - 10, SCSAH20 - 10